

# INSTALLATION, OPERATION & MAINTENANCE MANUAL

## PLASMA AIR MODEL 200 SERIES (MODELS 201D, 201E, 202D, 202E)

REV 11/2010



## INTRODUCTION

Plasma Air model 200 series air ion generators are two tube commercial quality units intended for installation in air handling units (AHU), furnaces, or duct systems for residential and commercial applications.

This ionization equipment is effective in reducing harmful pollutants and odors by introducing positive and negative ions into the system airflow. The number of units and the size of the ionization tubes are dependent on the airflow in the system and the severity of the pollution problem. See chart on the back of this manual for selection criteria.

## MECHANICAL INSTALLATION INSTRUCTIONS

### GENERAL MOUNTING LOCATION CRITERIA:

**Warning:** To reduce the risk of fire, this unit should not be installed downstream of a humidifier or exposed to other sources of moisture.

**Caution:** This product is suitable for mounting into duct of metallic construction only. Installation must be such that the structural integrity of the ducting is not compromised.

Mount units to allow access to the ionization level adjustment knob and for general maintenance. This product shall not be installed behind a suspended floor/ceiling or a structural wall, ceiling, or floor.

This product should not be mounted in a location where the air temperature exceeds 140° F. This usually means that it should not be installed at the outlet of a gas or oil fired furnace.

- 1) Screw the ionization tubes into the back of the transformer while gently holding the grounding clip away from the tube.
- 2) For residential installations, the preferred location is in the supply air duct leaving the AHU. Be sure to pick a location before any branch duct take-offs. Verify that there is sufficient duct depth to allow clearance for the tube – see figure 1.

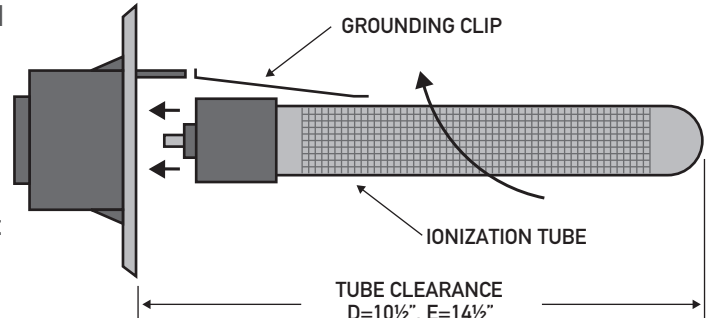
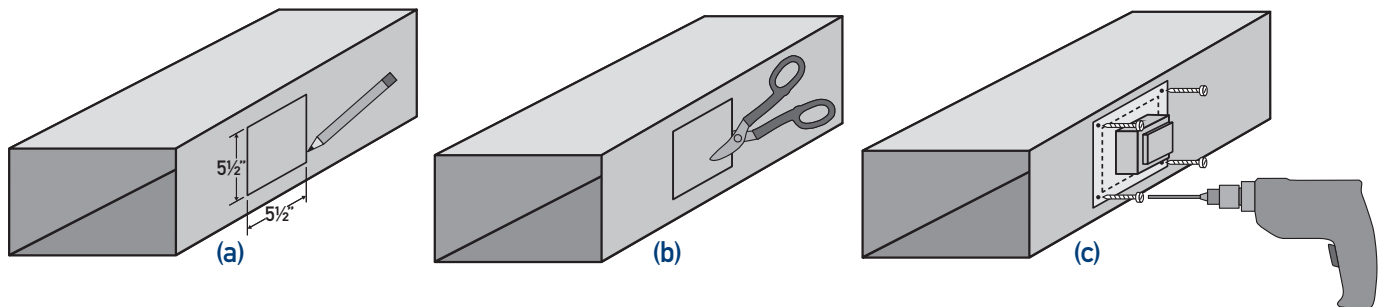

FIGURE 1 – MODEL 200 AND IONIZATION TUBE

### To mount the units in a duct:

- a) Trace a 5½" by 5½" square on the surface of the duct onto which you are mounting the model 200. The units have a flange gasket that forms a seal between the duct and the mounting plate.
- b) Cut out the traced portion of the duct using snips or sheet metal shears.
- c) Screw the model 200 onto the duct using sheet metal screws.



- 3) If the unit cannot be installed in the preferred location due to space or temperature limitations, see Figure 2 for alternate locations. Units can be installed using "L" shaped brackets available from many hardware suppliers or by cutting a hole in the AHU or furnace casing.
- 4) For commercial applications, the units are not typically mounted in the supply air duct as these ducts may not be easily accessible for tube replacement or other service. Units are commonly mounted inside a roof top AHU using "L" shaped brackets available at many hardware suppliers. Be sure to select a location within the air handling unit where there is good air flow. One such location is immediately next to the fan inlet.

### Mounting location notes:

- Ensure sufficient airflow over the ionization tubes.
- Do not mount the units before the system filter.
- Do not mount downstream of a gas or oil fired furnace.
- Avoid locations where moisture may be present like downstream of a cooling coil.

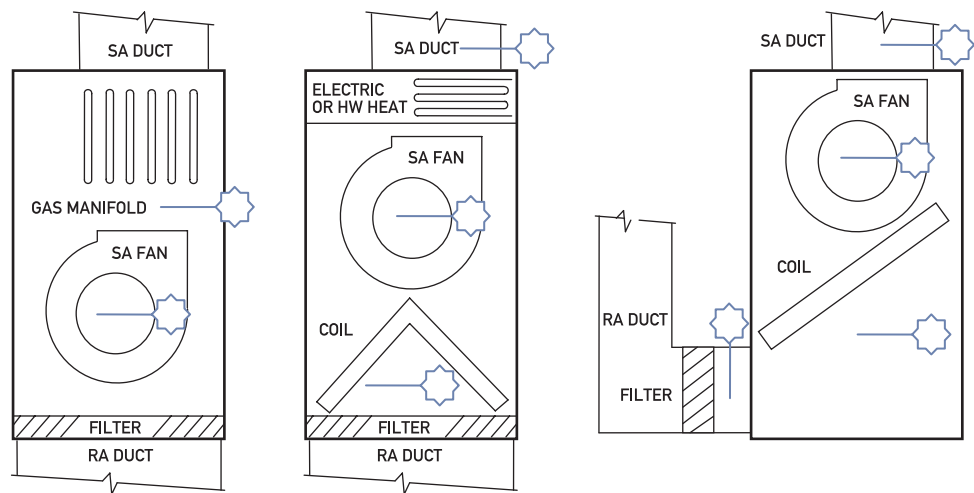

FIGURE 2 - SUGGESTED MOUNTING LOCATIONS IN A TYPICAL AHU OR FURNACE

## ELECTRICAL INSTALLATION INSTRUCTIONS

**Warning:** The secondary voltage at the ionizing tubes can be 3,000 Volts AC. Do not connect to power before the installation is complete. Always disconnect power to the unit before handling any of the unit components.

To reduce the risk of electric shock, this equipment has a grounding type plug that has a third (grounding) pin. This plug will only fit into a grounding type power outlet. If the plug does not fit into the outlet, contact qualified personnel to install the proper outlet. Do not alter the plug in any way.

- 1) The Model 200 is available in two primary voltage models, nominally 120 volts AC (model 201) or 230 volts AC (model 202). The units may be used on 50 cycle or 60 cycle frequencies. Verify that the model 200's voltage is the same as the available voltage by checking the UL label on the unit.
- 2) The typical model 200 unit draws about 20 Watts. The power source should not be protected by a breaker exceeding 20 amps.
- 3) The unit should be powered when the system supply fan is energized. This can be accomplished by any of the following methods:
  - On systems with single speed supply fans, the fan power supply can be used.
  - Use an airflow switch in series with the unit's power supply.
  - Install a relay off the 24 volt fan control circuitry and wire the unit's power wiring through the NO contacts
  - Install a supply fan power current sensing relay and wire the unit's power wiring through the NO contacts
  - Wire into the "EC" (Electronic Air Cleaner) contacts provided on the AHU.
  - On systems where the above fan interlocking options are not available, contact your distributor/dealer or Plasma Air directly for an AFS-MF unit. This product is a mounting frame with an integral pressure differential switch that allows the unit to be plugged into any 120 volt receptacle.

## OPERATION

The ionization adjustment knob is a six-position switch that is used to turn the unit on and adjust the level of ionization.

- 1) When the knob is in the "0" position, no power is being applied to the ionization tube and the green light is off. Rotating the knob from "0" through "5" increases the ionization output and will illuminate the green light.
- 2) The ionization level is set by the installing contractor and does not require adjustment on a regular basis. A guide is provided on the back cover of this manual to set the ionization level based on the Pollutant Load Factor.
- 3) The benefit of the ionization system is only realized when the supply fan is running. So to achieve improved air quality, run the fan continuously or use an IAQ type thermostat such as a Lux model CAG 1500 which will cycle the fan once an hour at specified times of the day.

## MAINTENANCE

**Warning:** The secondary voltage to the ionizing tubes can be 3,000 Volts AC. Always disconnect power to the unit and switch the power to the “off” position before performing any maintenance.

Tubes are rated for approximately one (1) year of service and should be replaced at that interval. Contact your local Plasma Air Distributor/Dealer to purchase replacement tubes, [www.plasma-air.com](http://www.plasma-air.com).

## TROUBLESHOOTING

If the unit is not working, check in the following order that:

- 1) The ionization adjustment knob is in between “1” and “5” and that the green light illuminates.
- 2) The 0.5 Amp. glass cartridge fuse is not blown. The fuse is located under the power cord. The fuses are 5mm x 20mm rated at 250 Volts and are available at any electrical supply store.
- 3) If the unit fuse is blown, remove the tube and replace the fuse. Turn on power to the unit. If the fuse blows again, return the unit to the distributor for factory service.
- 4) If the fuse does not blow, the most likely problem is a defective tube. Carefully inspect the tube for cracks. Although rare, cracks are usually found at the capped end of the tube.
- 5) If the tube has been subjected to high temperatures, above 140° F, there is a possibility of a pin hole. These are difficult to spot, but can cause shorting of the tube. Install the tube into the unit and power the unit. If the fuse blows, the tube is defective and requires replacement.
- 6) If the tubes are more than a year old, replace them.

## PRODUCT SELECTION

When using Plasma Air ionization equipment on any project, it is important to provide the proper amount of ionization. In commercial or industrial projects, pollutants such as airborne particles from smoke, dust, spores; VOCs from cleaning supplies, glues, paints, or other chemicals; odors from locker rooms, cooking, nursing homes, industrial processes; and even health related concerns from mold, bacteria, and viruses all contribute to poor indoor air quality. Selecting the proper ionization equipment is important for achieving all the benefits from the ionization system. The information below will guide you through the process.

POLLUTANT LOAD FACTOR	
A	Normal residential, office, or classroom space - low pollutant levels
B	Casino, day care center, nursing home, food processing facility, restaurant - medium pollutant levels
C	Animal hospital, light manufacturing, smoking areas, nail/beauty salons - heavy pollutant levels
D	Industrial facility, heavy manufacturing, or garbage room - very heavy pollutant levels
E	Heavy pollution or odors typical of a waste water treatment facility

### SQUARE FOOTAGE SERVED BY AIR HANDLER

		1,000	2,000	3,000	5,000	10,000	20,000
POLLUTANT LOAD FACTOR	A	(1) 100C	(1) 100D	(1) 100E	(1) 200E	(1) 50F	(2) 50F
	B	(1) 100D	(1) 100E	(1) 200E	(1) 50E	(2) 50E	(3) 50F
	C	(1) 100E	(1) 200E	(1) 50E	(2) 50E	(3) 50F	(6) 50F
	D*	(1) 200E	(1) 50E	(1) 50F	(2) 50F	(4) 50F	(8) 50F
	E*	*Consult Plasma Air Engineering Department for Engineering Support					

©2008 PLASMA AIR INTERNATIONAL

Notes: The ionization control knob can be used to fine tune space ionization levels.  
The Model 100 has one (1) ionization tube and the Model 200 has two (2) ionization tubes.



**PLASMA AIR**  
INTERNATIONAL

PLASMA AIR INTERNATIONAL 35 MELROSE PLACE STAMFORD, CT 06902  
203-662-0800 ph 203-662-0808 fax info@plasma-air.com www.plasma-air.com